

Making life **EZI...**for Plumbers



EZIPEX SLIDE™

WATER & GAS SOLUTIONS

CONTENTS

2	Overview
3	Application
4 – 8	Pipe
9	Fittings
10	Features & Benefits
11 – 15	Installation Considerations
16 – 20	Joining Instructions
21 – 26	EZIPEX Slide™ Fitting Range
27	EZIPEX Slide™ Tools
28	Notes
29	Warranty

Making life **EZI...**for Plumbers

Overview

The EZIPEX Slide™ system has been developed to deliver plumbers, builders and home owners a high quality yet cost effective pipe system for use with hot and cold water, rainwater, hydronic heating and recycled water distribution.

One of the key requirements was the need for a quick and effective jointing method combined with the peace of mind provided by the performance benefits of our EZIPEX™ pipe.

EZIPEX Slide™ joins EZIPEX Crimp™, EZIPEX Push™ and EZIPEX Gas™ to provide a total solution for all your water and gas applications.

The EZIPEX™ product range is based on a premium quality cross-linked polyethylene pipe which is used in conjunction with either of our 3 available ranges of DZR brass fittings, Slide, Crimp and Push.

All installations should be carried out by an appropriately licensed tradesperson and in full accordance with the EZIPEX Slide™ installation guidelines, the relevant Australian standards and any additional local authority requirements. When installed subject to the above conditions the EZIPEX Slide™ system will provide years of trouble free service.

Application

The EZIPEX Slide™ system is an axial crimp system (more commonly known as a compression system) to produce a secure joint in a minimal amount of time. This method involves drawing a sleeve along the pipe over a barbed fitting to form a perfect seal every time, and eliminates the need for call backs to repair partially welded joints etc.

EZIPEX Slide™ Water fittings may be used in accordance with AS/NZS 3500 for water applications including:

- Hot and Cold Potable Water,
- Rainwater,
- Recycled Water (non-potable), and
- Hydronic Heating.

For optimum performance results please take the time to become familiar with the installation considerations outlined on Pages 11-15 in this booklet.

Pipe

EZIPEX™ pipe is a high quality PEX-a cross linked polyethylene pipe. In general terms, polyethylene in its normal state is not capable of handling high pressure or temperature loads. However once subjected to the cross-linking process, its ability to handle these conditions is increased substantially.

EZIPEX™ pipe consists of an inner section of PEX-a material encased in an outer layer of tough HDPE.

EZIPEX™ also offers a pipe specifically for use in hydronic heating. This pipe is identified by its bright orange colour. EZIPEX™ orange pipe is a similar construction to the standard EZIPEX™ pipes. However, it also incorporates a layer of EVOH material which acts as an oxygen barrier, thus preventing the entry of additional oxygen into the sealed heating system.

EZIPEX™ pipe is available in the following sizes: DN16, DN20, DN25, DN32, in either coil form or straight lengths.

EZIPEX™ pipe is warranted for use with potable water and glycol solutions only. Contact your local EZIPEX™ supplier for more information and applications for use with other fluids.







EZIPEX™ pipe - standard supply units

Nom Pipe size	Straight Lengths (all)	Coil length (black)	Coil length (red)	Coil length (green)	Coil length (lilac)	Coil length (orange)
16mm	5m	50m 100m	50m 100m	50m 100m	50m	200m
16mm (In Conduit)		50m	50m			
20mm	5m	50m 100m	50m 100m	50m 100m	50m	
20mm (In Conduit)		50m			50m	
25mm	5m	50m	50m	50m		
32mm	5m	25m		25m		
16mm (Conduit only)		50m				
20mm (Conduit only)		50m				
25mm (Conduit only)		50m				
32mm (Conduit only)		25m				

The EZIPEX™ pipe is colour coded to assist the installer in avoiding cross connections.

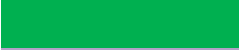

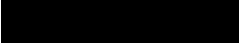
	BLACK	Hot & cold potable water
	RED	Hot water
	GREEN	Rainwater
	LILAC	Recycled water (non-potable)
	ORANGE	Hydronic heating
	CONDUIT	In/under slab hot & cold water

EZIPEX™ pipe dimensions

Nom Size	Mean OD (mm)	Mean Wall Thickness (mm)
16mm	16.15	2.20
20mm	20.15	2.80
25mm	25.15	3.50
32mm	32.15	4.40

Performance

EZIPEX™ pipe provides users with many advantages over traditional piping materials. It has excellent flexibility, offers a high degree of resistance to damage caused by freezing, offers excellent pressure and temperature resistance, is lightweight and also has low noise and heat transmission qualities. EZIPEX™ pipe provides very low levels of friction loss and therefore can often save users the need to upsize piping when installing long runs. As jointing methods are mechanical, it does not require the use of solvents. Nor does it require soldering, welding or brazing.

EZIPEX™ pipe heat & pressure performance

AS/NZS 2492

Recommended working pressure relative to pipe material temperature

Temp (°C)	20	40	60	70
Pressure (Kpa)	2000	1800	1500	1330

Cross-section

Black, Red, Green, Lilac pipe

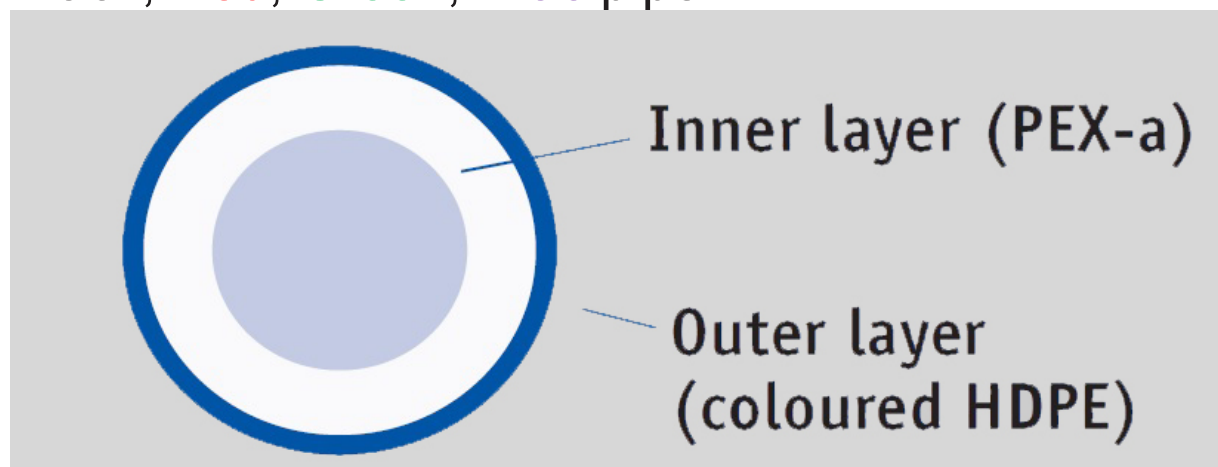

1. Inner layer: combination of HDPE & cross linking agent.
2. Outer layer: HDPE compound. (Note that Red & Green pipe have two outer layers to meet opacity requirements.)

Orange pipe

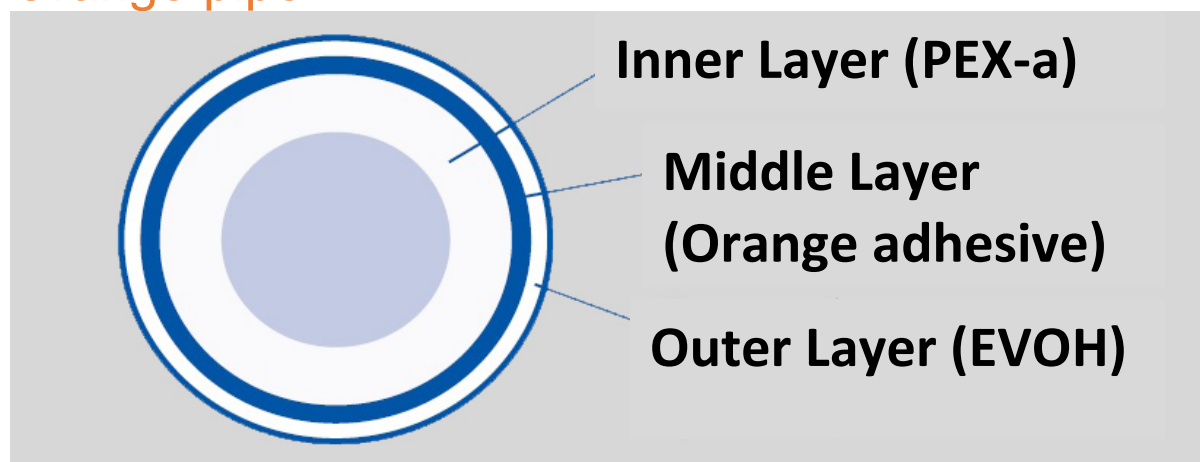

1. Inner layer: the same PEX-a layer as standard EZIPEX™ pipe.
2. Middle layer: coloured adhesive to bind internal PEX-a layer to the external EVOH layer(<0.13mm).
3. Oxygen barrier (<0.01mm). Clear outer layer which prevents oxygen from permeating through the pipe from the outside atmosphere.

Fittings

EZIPEX Slide™ fittings bodies are manufactured from DZR brass which provides exceptional resistance to corrosion.

All EZIPEX Slide™ fittings are manufactured and certified to AS/NZS 2537 – mechanical joint fittings for use with EZIPEX PEX-a pipe for hot & cold water applications.

EZIPEX Slide™ fitting dimensions

Nom Size	Mean Bore (mm)
16mm	10
20mm	12.5
25mm	15.3
32mm	20

Features and Benefits

Compression Jointing Method

- Fast
- Secure
- Simple to use
- Less time on the job
- Less capital outlay on tooling
- Internal sealing method reduces leaks due to scratched pipe

Stock Consolidation

- Same pipe for EZIPEX Push™, EZIPEX Slide™ & EZIPEX Crimp™
- One pipe, 3 systems

Flame-free Assembly

- Increased safety
- No need for gas cylinders or Hot Works permits
- Reduced costs on welding consumables

Size Range DN15 – DN32

- Fittings available for most tasks

Acoustics

- Low noise transmissions in PEX-a pipe
- Quieter, reduced water hammer

Installation Considerations

EZIPEX Slide™ should always be installed in compliance with AS/NZS 3500. Most installation requirements can be sourced from this document.

Proximity to flame / external heat sources

The EZIPEX Slide™ system should not be installed in positions where it is likely to be exposed to a naked flame. If it is, there's a danger the pipe could ignite and continue to burn even after the source of the flame is extinguished. In accordance with AS/NZS 3500 all plastic pipes for water supply must be protected from excessive ambient heat.

Thermal expansion

EZIPEX™ pipe has an expansion rate of approximately 1.5mm per metre for every 10°C change in temperature. This expansion or contraction should be taken into consideration for any installation and the appropriate allowances made in pipe layout or fixing positions. Care should be taken not to pull the pipe tightly between fixed points during installation as the pipe may later contract causing excessive tensile force to any joints. This could cause a joint failure.

Heat & Pressure performance

As with all plastic pipe systems the ability of the pipe to withstand pressure decreases as the pipe temperature increases. *(Refer to table on page 7)*

Protection from physical damage

Due care should be taken to protect pipe and fittings from any physical damage both prior to, during and after installation. Possible causes of physical damage may include (but are not limited to) sharp edges or implements, machinery, rodents, excessive heat, long term UV exposure, radiation, mechanical forces, corrosive agents and high levels of chlorine and other chemicals that may have a detrimental effect on the piping system. EZIPEX™ brass fitting should not come in contact with treated pine.

Both during and after installation, the product should not be damaged by grouting or stress caused by concrete stress cracks or any other external force.

Framework Penetrations

Where EZIPEX™ pipe penetrates timber or metal framework, appropriate precautions should be taken to protect it from damage. Holes should be sized to allow for longitudinal movement, expansion and contraction of pipe whilst still securing the pipe adequately. Suitable grommets or sleeves should be used in metal frames to protect the pipe from abrasion.

Pipe Bending

Do not apply bending forces to joints which have already been completed. Finish all bending operations prior to installing the fitting.

Due care should be taken during bending to ensure that the pipe is not damaged or kinked. If you do encounter a kinked or damaged section of pipe, it should be cut out and replaced as a precaution. The use of bend supports is recommended where required.

EZIPEX™ pipe can be bent easily by hand. The radius of the bend should be not less than 8 times the diameter of the pipe.

Minimum Bending Radius

Nom Size	Min Bending Radius (mm)
16mm	130
20mm	162
25mm	202
32mm	258

Clipping

In accordance with AS/NZS 3500, fixing spacing should be observed for both horizontal and vertical pipe runs as outlined in the table below.

Clipping should be by way of a recognized fixing which complies with the requirements of AS/NZS 3500. This excludes things such as bent-over nails, tie wire, pierced metal strapping, etc. It is recommended that EZIPEX™ pipe is installed using a PEX Clip to ensure secure fastening of pipe in a manner that will not exert stress on the fittings caused by thermal expansion and contraction of pipe.

Clip Spacing Table

Nom Size	Vertical Run Spacing (m)	Horizontal Run Spacing (m)
16mm	1.2m	0.6m
20mm	1.4m	0.7m
25mm	1.5m	0.75m
32mm	1.7m	0.85m

Underground

Pipe should be buried with a minimum cover of 450mm. Marker tape should be installed approximately 150mm above the pipe. Additional precautions, such as wrapping of the pipe, should be taken in areas where aggressive soil conditions are known to exist or where it may be a requirement of the local certifying authority. The use of “Blue Metal” or “Crusher Dust” as a backfill material is to be avoided. Ground needs to be inspected to ensure it is not contaminated prior to burial of the pipe, and care should be taken to ensure that post installation contamination does not occur.

When being buried beneath a building, the pipe should be free of joints.

Chases, In-Slab, Under-floor

Where EZIPEX™ pipe is installed in chases or cast in slabs, the installation must be in accordance with both AS/NZS 3500 and any other relevant building regulations or standards.

A convenient and cost effective solution for these applications is the EZIPEX™ pipe pre-sleeved in durable and flexible polyethylene corrugated conduit – available as part of the EZIPEX™ piping range.

UV Exposure

All EZIPEX™ pipe should be protected from long term exposure to UV by way of either lagging or enclosing in a conduit.

Note: Additional thermal lagging may also be required to protect any of the pipes from temperature extremes.

Hot Water Ring Mains

In larger homes and commercial buildings hot ring mains are commonly used to decrease the time it takes for hot water to be delivered to the various outlets, especially those that are a significant distance from the hot water heater. Given the continuous high temperature and circulation of water within the pipe work these are demanding applications for all piping systems, including PEX. To ensure the service life of PEX used in the flow and return pipework in a recirculating ring main the following installation practices and operating parameters must be met.

- Maximum water temperature of 60°C (measured, not set point).
- Maximum water pressure of 500kPa (as per AS/NZ3500)
- Maximum water velocity to the requirement of AS 3500 for non-metallic piping.
- Circulation time is to be limited to 12 hours per 24-hour period by means of timer operated pump.
- The pipe work must be lagged, and it is recommended to use a thermostat-controlled recirculation pump.

Testing

In all installations at the completion of rough-in, pressure testing must be carried out in accordance with AS/NZS 3500 for water installations and in addition to any other local regulations or requirements.

During testing all joints should be checked for leaks, prior to burying or concealing the EZIPEX Slide™ system.

Jointing instructions

Tools



Pipe Cutters



Jointing Tool



Expanding Tool

Terminology

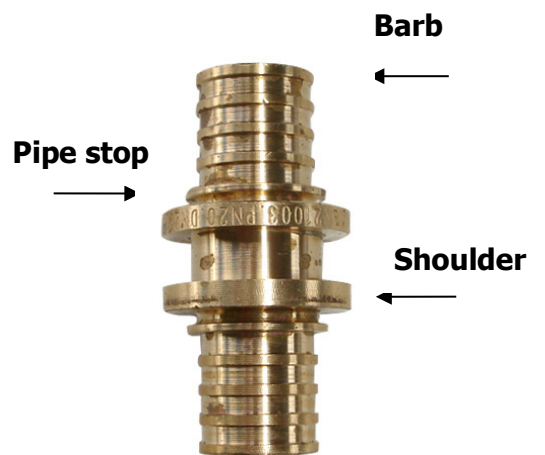
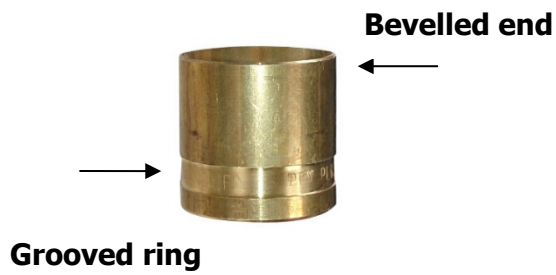

1. Cut pipe

Cut pipe to desired length. Cut should be square and free from any swarf or burrs. Use REMS pipe cutter or similar blade type cutter. Do not use a hacksaw as this creates excessive swarf.



2. Pipe Expansion

Pipe must be expanded by using the EZIPEX™ expander. Ensure that the expander heads are not faulty or broken as this will lead to the joint eventually leaking.

- i. Holding the levers of the Expanding Tool fully open, screw on the expander head. Ensure that the expander head is screwed on fully.



- ii. Slip the jointing sleeve over the pipe with its bevelled end facing towards the fitting being joined.

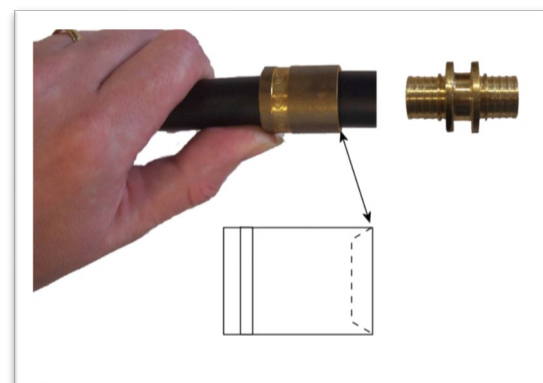

- iii. Insert the expander head into pipe, ensuring that the expander is at right angles to the pipe. Ensure that the jointing sleeve is well clear of the area that is to be expanded.



- iv. To expand the pipe, fully close the levers of the expanding tool. Hold them in position momentarily then release and rotate pipe or expander approximately 30° and repeat the process. This ensures that the inside pipe surface is expanded evenly.

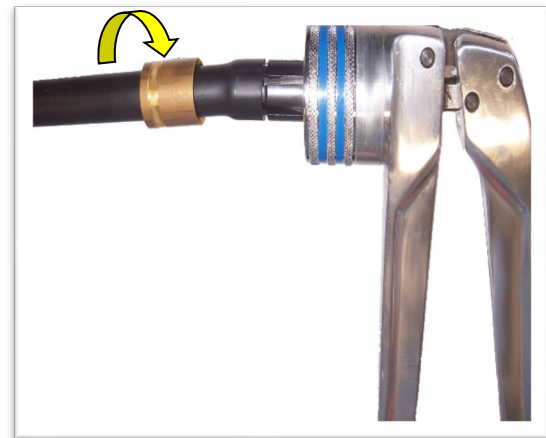

Note: It should not be necessary to expand more than twice. Over or under expansion of the pipe can lead to possible joint failure.

3. Joint assembly

Insert the fitting into the expanded pipe until the pipe reaches the pipe stop - It does not need to reach to the shoulder. After a few moments the pipe will shrink and grip the fitting. Slide the jointing sleeve as far as you can towards the fitting.



4. Completion of joint

The recommended EZIPEX Slide™ compression tool is to be used. Ensure that the tool is not damaged. Use of a damaged or non-complying tool will void warranty.

- i. Position the jointing sleeve and fitting squarely within the jaws of the jointing tool.

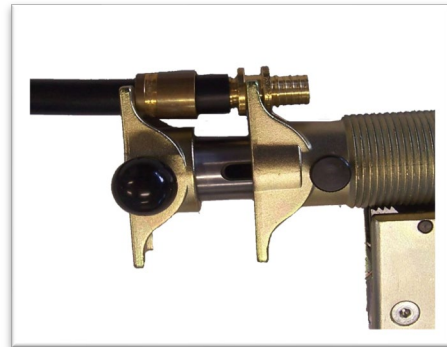

- ii. Draw the sleeve towards the fitting by closing the jaws of the jointing tool.

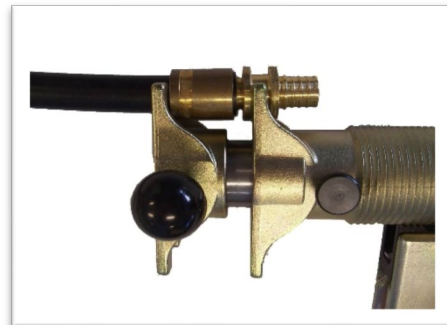

- iii. The jointing sleeve is drawn over the pipe until it reaches the shoulder of the fitting.



5. Inspection

All joints are to be visually inspected once installation is complete. Ensure that the sleeves are drawn all the way to the fitting shoulder and that they are secured with the bevelled end closest to the fitting and the grooved ring at the furthest point from the fitting shoulder.

6. Pressure test

At completion, carry out pressure testing. All testing should be undertaken in accordance with AS/NZS 3500 (for water installations) and or in addition to any other local regulations or requirements.

EZIPEX Slide™ Fittings

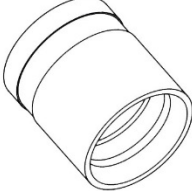
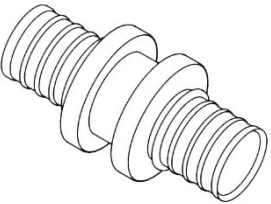
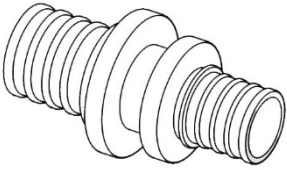
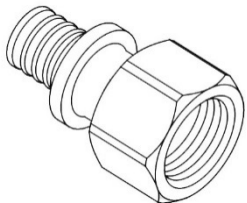
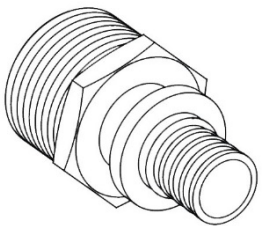
PRODUCT DESCRIPTION	SIZE	PART #
COMPRESSION SLEEVE 	DN16	235090
	DN20	235091
	DN25	235092
	DN32	235093
#1 STRAIGHT COUPLING 	DN16	235096
	DN20	235097
	DN25	235098
	DN32	235099
#1R REDUCING COUPLING 	DN20 X DN16	235102
	DN25 X DN16	235103
	DN25 X DN20	235104
	DN32 X DN25	235105
#2 STRAIGHT CONNECTOR 	DN16 X 15BSPF	235149
	DN20 X 15BSPF	235150
	DN20 X 20BSPF	235151
#3 STRAIGHT CONNECTOR 	DN16 X 15BSPM	235154
	DN16 X 20BSPM	235152
	DN20 X 15BSPM	235155
	DN20 X 20BSPM	235156
	DN20 X 25BSPM	235153
	DN25 X 15BSPM	235157
	DN25 X 20BSPM	235158
	DN25 X 25BSPM	235159
	DN32 X 20BSPM	235160
	DN32 X 25BSPM	235161

EZIPEX Slide™ Fittings

PRODUCT DESCRIPTION	SIZE	PART #
---------------------	------	--------

#12 ELBOW

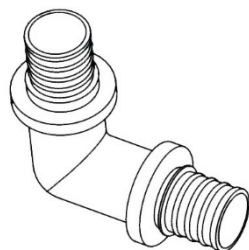

DN16	235108
DN20	235109
DN25	235110
DN32	235111

#13 MALE ELBOW

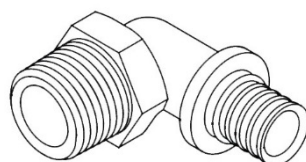

DN16 X 15BSPM	235163
DN20 X 15BSPM	235164
DN20 X 20BSPM	235165
DN25 X 20BSPM	235166
DN25 X 25BSPM	235167

#14 FEMALE ELBOW

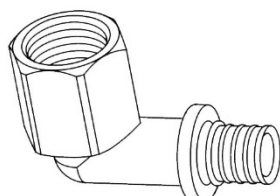

DN16 X 15BSPF	235169
DN20 X 15BSPF	235170
DN20 X 20BSPF	235171

#15BP ELBOW

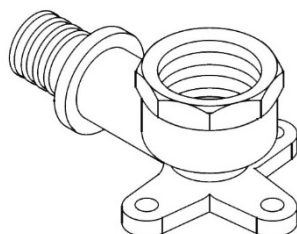

DN16 X 15BSPF	235178
DN20 X 20BSPF	235177
DN20 X 15BSPF	2351770

EZIPEX Slide™ Fittings

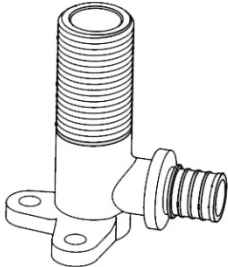
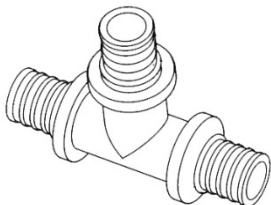
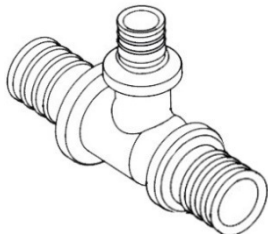
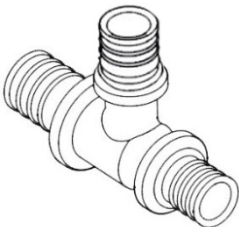
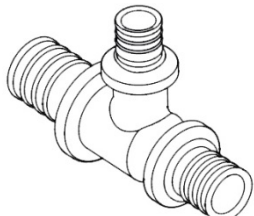
PRODUCT DESCRIPTION	SIZE	PART #
#19BP ELBOW 	DN16 X 15BSPM X 65mm long	235179
	DN16 X 15BSPM X 90mm long	235176
	DN16 X 15BSPM X 200mm long	235174
	DN16 X 15BSPM X 150mm long	235175
	DN20 X 15BSPM X 95mm long	235173
	DN20 X 15BSPM X 200mm long	235180
	DN20 X 20BSPM X 200mm long	235181
	<hr/>	
#24 TEE EQUAL 	DN16	235114
	DN20	235115
	DN25	235116
	DN32	235117
	<hr/>	
#25 TEE RED. BRANCH 	DN20 X DN20 X DN16	235120
	DN25 X DN25 X DN16	235121
	DN25 X DN25 X DN20	235122
	DN32 X DN32 X DN25	235123
	<hr/>	
#26 TEE RED. END 	DN20 X DN16 X DN20	235126
	DN25 X DN16 X DN25	235127
	DN25 X DN20 X DN25	235128
	<hr/>	
#27 TEE RED. CENTRE & END 	DN20 X DN16 X DN16	235132
	DN25 X DN16 X DN16	235133
	DN25 X DN20 X DN16	235134
	DN25 X DN16 X DN20	235135
	DN25 X DN20 X DN20	235136
	DN32 X DN25 X DN25	235137
	<hr/>	

EZIPEX Slide™ Fittings

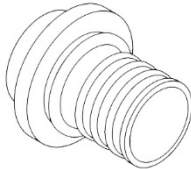
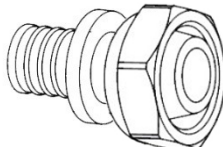
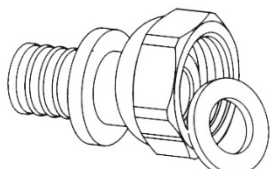
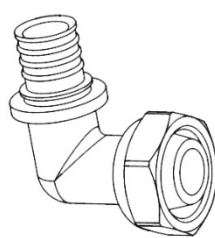
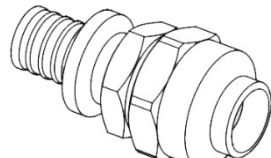
PRODUCT DESCRIPTION	SIZE	PART #
#61 STOPPER 	DN16	235204
	DN20	235205
#62 STRAIGHT TAP CONNECTOR CONE 	DN16 X 15BSPF	2351831
	DN20 X 20BSPF	2351841
#62 STRAIGHT TAP CONNECTOR FLAT 	DN16 X 15BSPF	235183
	DN20 X 20BSPF	235184
#63 BENT TAP CONNECTOR 	DN16 X 15BSPF	235185
	DN20 X 20BSPF	235186
FLARED COPPER COMPRESSION UNION 	DN16 X 15FL	235094
	DN20 X 20FL	235095

EZIPEX Slide™ Fittings

PRODUCT DESCRIPTION	SIZE	PART #
---------------------	------	--------

CONNECTING BARB x CU SPIGOT

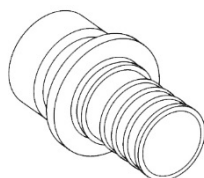

DN16	235145
DN20	235146
DN25	235147
DN32	235148

CONNECTING BARB x CU SOCKET

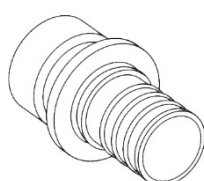

DN16	235215
DN20	235216
DN25	235217
DN32	235218

SHOWER ASSEMBLY RIGHT ANGLE

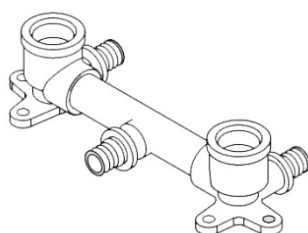

150mm Centres	235195
200mm Centres	235199

SHOWER ASSEMBLY RIGHT ANGLE BARBS UP

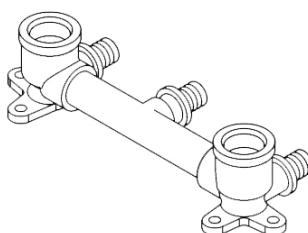

150mm Centres	235197
200mm Centres	235198

SHOWER ASSEMBLY STRAIGHT

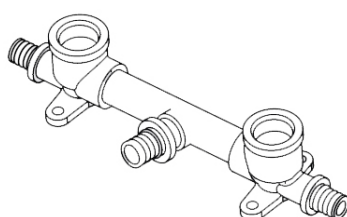

150mm Centres	235196
---------------	--------

EZIPEX Slide™ Fittings

PRODUCT DESCRIPTION	SIZE	PART #
---------------------	------	--------

BATH LAUNDRY ASSEMBLY RIGHT ANGLE	300mm Centres	235193
	200mm Centres	235194

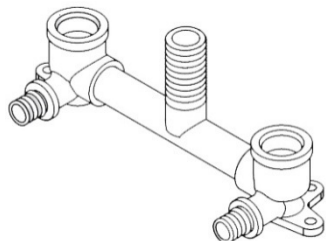

BATH LAUNDRY ASSEMBLY STRAIGHT	300mm Centres	235192
---------------------------------------	---------------	--------

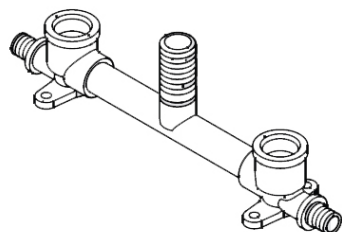

EZIPEX Slide™ Tools



REMS Ax-Press 25 ACC – For EZIPEX Slide™ sizes DN16 to DN32

Super light, super handy. Fast. With automatic return. Optimum weight distribution for single-hand operation. Swivelling compression device. Complete assortment of REMS compression heads for EZIPEX Slide™



Jointing Tool - For EZIPEX Slide™ sizes DN16 to DN32



Expanding Tool - For EZIPEX Slide™ sizes DN16 to DN32

For alternative tools, see your local EZIPEX Slide™ distributor...or visit ezipex.com.au

Disclaimer

Information provided in this publication is intended to be of a general nature only and is provided as a guide. Installation requirements may vary across different product applications or in different jurisdictions. Information provided does not in any way override that contained in the relevant Australian Standards for either product or installation practice.

Notes

20 horizontal grey bars for taking notes.



25 Year Warranty

This product is supplied with a 25-year warranty against any manufacturing defects. The period of the Warranty commences on the date of sale and ends on the anniversary of the date of sale. Any defective product will be repaired or replaced free of charge.

Warranty Conditions

- Installation must have been carried out by a licensed plumber and gasfitter.
- Failure is due to a fault in the manufacture of the product.
- Installation of the product has been in accordance with the installation instructions as per the current (at time of installation) EZIPEX™ Technical Manual.
- Installation must be in full accordance with the relevant local and National Plumbing codes and appropriate Australian Standards (AS/NZS 3500).
- The system in which the product is installed must not be operated at temperatures and or pressures that exceed the printed rating on the appropriate specification sheet.
- This warranty does not extend to failure or defect caused by normal wear and tear, mechanical overload, paint, adhesives, abrasion, corrosion or over pressurization.
- No liability will be accepted for loss of profits, loss of revenue, loss of use, loss of contracts, loss of production or any other consequential loss or damage.

Claim Procedure

- This Warranty is offered by the manufacturers of the EZIPEX™ pipe and fittings and the Plumbing Plus Merchant (“**Merchant**”) from whom you purchased the product. The Merchant involved should be notified of any potential claim immediately. Proof of purchase is required to validate the warranty period and if this is not available, the warranty period shall default to the date of manufacture for each product. The product needs to be inspected by an authorized representative of the manufacturer within 30 days of the alleged product failure.
- To be entitled to claim under this Warranty, you must send a Warranty Claim Form to the Merchant.
- Should product be returned, a sufficient length of pipe must be supplied so that all the pipe markings are visible. Should a fitting be returned, it must be supplied with the pipe still attached with sufficient length of pipe to show the markings.
- If the Merchant needs to return the goods to the manufacturer for assessment or repair, the Merchant will arrange delivery and bear the associated costs.
- The manufacturer and the Merchant also reserve the right to engage a nominated outside agent to assess any faulty product before honouring any warranty claim.
- Once a reasonable pre-approved amount is confirmed in writing by the manufacturer, repairs can begin.
- Any repairs or replacement undertaken without the manufacturer’s or the Merchant’s approval will not be covered by this Warranty.

Exclusions

Plumbing Plus BKL Pty. Ltd. is not a party to this Warranty Agreement.

Australian Consumer Law

Our goods come with guarantees that cannot be excluded under the Australian Consumer Law (ACL). For instance, you may be entitled to a replacement or refund or entitled to have the goods repaired or replaced if they are defective.



WaterMark

Making
life **EZI...**
for
Plumbers



TECHNICAL MANUAL